

I N T R O D U C I N G

Worm Gear Mixer Drives

Reliable Power Transmission for
Mixers / Agitators



Delroyd's New Delivery Commitment from Order-to-Delivery in 3 Weeks!

**P30 - P40 - P50 - P60 &
HP40 - HP50 - HP60 Units**

This NEW delivery commitment is a result of:

- Capital Investment in New Machinery
- Improved Manufacturing Processes

Fluid mixing is often a very complex process. While the properties of the materials to be mixed, as well as the mixing vessel and agitator are very important considerations, the type of drive can greatly affect mixing costs - both operating and initial investment. For a wide variety of materials in chemical, process, pollution control and many other applications, Delroyd worm gear drives for mixers and agitators offer many advantages over the other types of gearing and drive units.



Design Features and Internal Construction

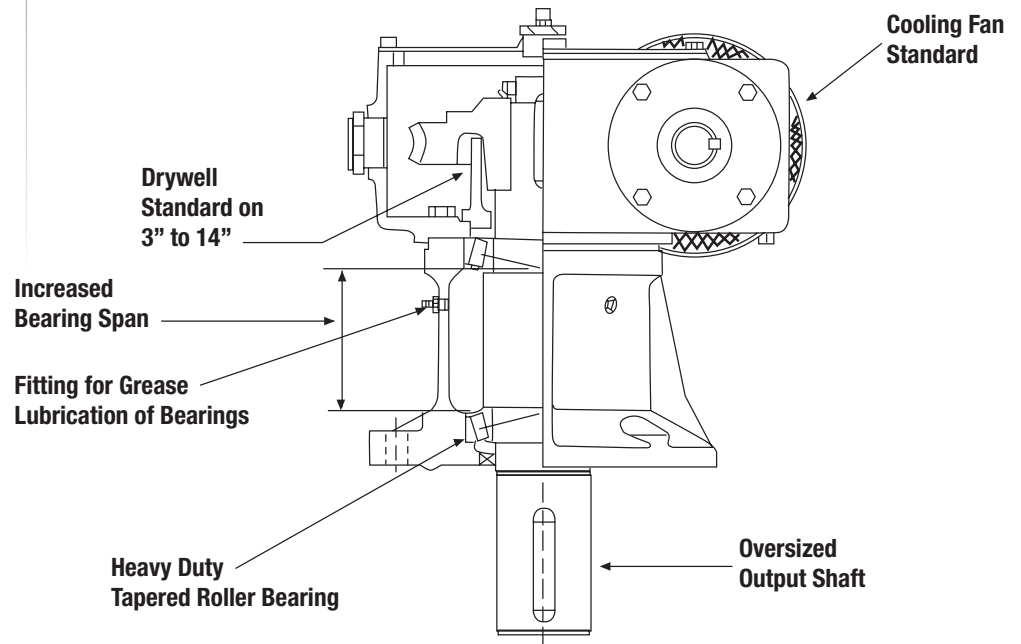

Worm Gear Mixer Drives Features

- Delroyd Unique Worm & Gear Design
 - Operation with multiple tooth contact
 - Shockless power delivery
 - Quiet operation (meets OSHA sound standards 76 to 80 DbA)
 - Provides economical & efficient at low speeds
- Available Single reductions from 5:1 through 70:1 for output speeds down to 25 rpm (standard 1750 rpm motors)
- Available Double reductions from 15:1 to 350:1 to provide outputs as low as 5 rpm
- Note: Gearing efficiency is quite different from mixing efficiency. Mixing efficiency is influenced by gearing efficiency
- Delroyd worm gear drives are engineered to withstand up to 300% momentary peak overloads and shock loads
- Delroyd mixer drives offer a minimum service factor of 1.25
- In Delroyd units, heavy-duty tapered roller bearings (B-10 life of over 10,000 hours on the worm shaft; B-10 life of 100,000 hours on low speed shaft) minimize shaft vibration and sensitivity to shaft deflection. This eliminates the need for hollow quill construction and lowers the overall cost of the mixer/agitator.
- The centrifugally cast phosphorous bronze gear mates with a hardened, ground and polished steel worm. As the drive operates, the bronze gear conforms and work-hardens to the contour of the worm. This is responsible for the saying that "Delroyd worm gears wear in, not wear out."
- Standard drywell construction provides positive protection against leakage of lubricants. There's no danger of product contamination.
- Standard Delroyd units range from 3 through 14-inch center distances, and horsepower from .132 to 265 HP.
- Drives with even larger center distances and greater horsepower are available.

Call our Toll-Free Application Hotline: 800-432-0121



www.delroyd.com

2221 Niagara Falls Boulevard
Niagara Falls, NY 14304 - USA
716-298-4100
Fax: 716-298-4101